

CHAPTER 2 - ATMOSPHERIC CIRCULATION & AIR/SEA INTERACTION

The atmosphere is driven by the variations of solar heating with latitude. The heat is transferred to the air by direct absorption to some extent but more importantly by (a) the absorption of long wave (or infrared) radiation from the ground and the sea (b) latent heating from evaporation of surface water and (c) the sensible heating from the surface. Thus most of the energy which drives the atmosphere comes from below.

Let us explore some of the principal features of the annual mean atmospheric circulation by considering the atmospheric circulation on a non-rotating Earth.

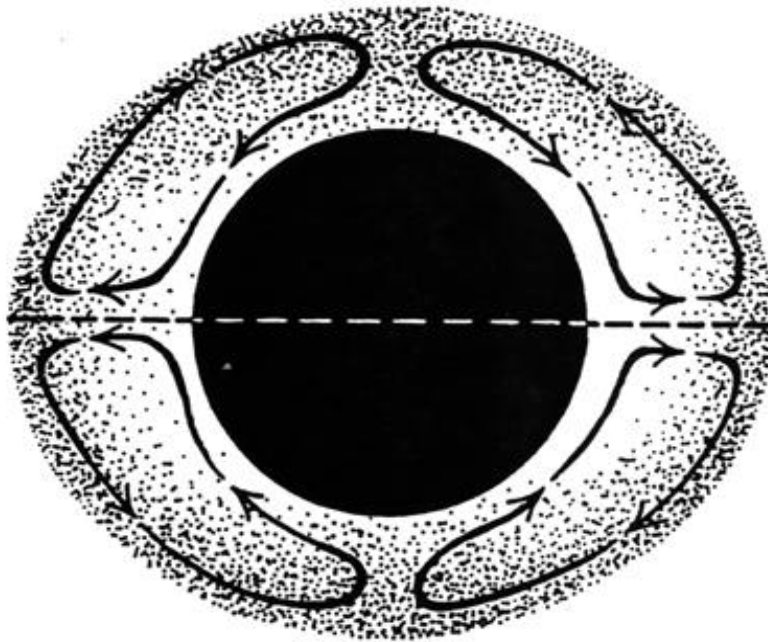

Figure 2.1. Idealized atmospheric circulation induced by solar radiation on a non-rotating Earth. (Ericson & Wollin, 1967)

Chapter 2 - pg. 2

First, the equator-to-pole (i.e. meridional) non-uniformity in the incoming solar radiation heat flux would generate a pair of convection-driven, spherical atmospheric circulation cells, like those seen in meridional vertical section in [Figure 2.1](#). The combination of heating-induced upward convection in the tropics, cooling-induced sinking in the polar regions and conservation of mass (i.e., continuity) are responsible for this hypothetical flow. However this picture does not consider the effects of Earth rotation.

On a rotating Earth, the direction of any air flow (i.e. wind) is strongly deflected by the so-called Coriolis effect according to the general rules illustrated in [Figure 2.2](#). (For now, this deflection can be thought of what one would observe on a rotating Earth as we move out from under the meridional air flows).

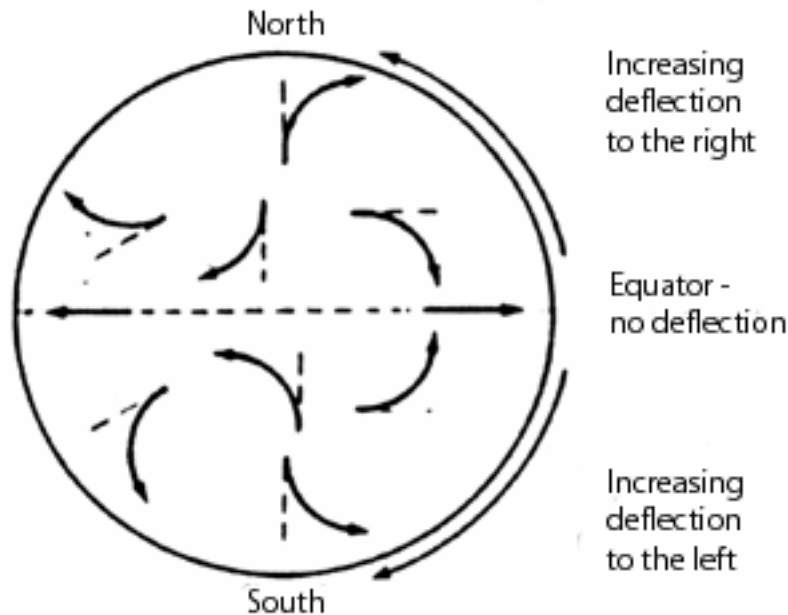

Figure 2.2. Paths of moving objects are deflected by the Coriolis effect. There is no deflection at the equator; the deflection increases toward the poles. [After A.N. Strahler, *Physical Geography*, 2nd ed. (New York: John Wiley & Sons, Inc., 1960), p. 129]

Chapter 2 - pg. 3

Planetary Winds

Earth rotation destabilizes the relatively simple dual cell flow pattern in Figure 2.1, resulting in the multi-cell pattern shown in Figure 2.3. The more realistic meridional air flow pattern consists of the Hadley cell between the equator and mid-latitudes and more complicated meridional flow patterns poleward. The surface wind patterns tend to be east-west trending (or zonal).

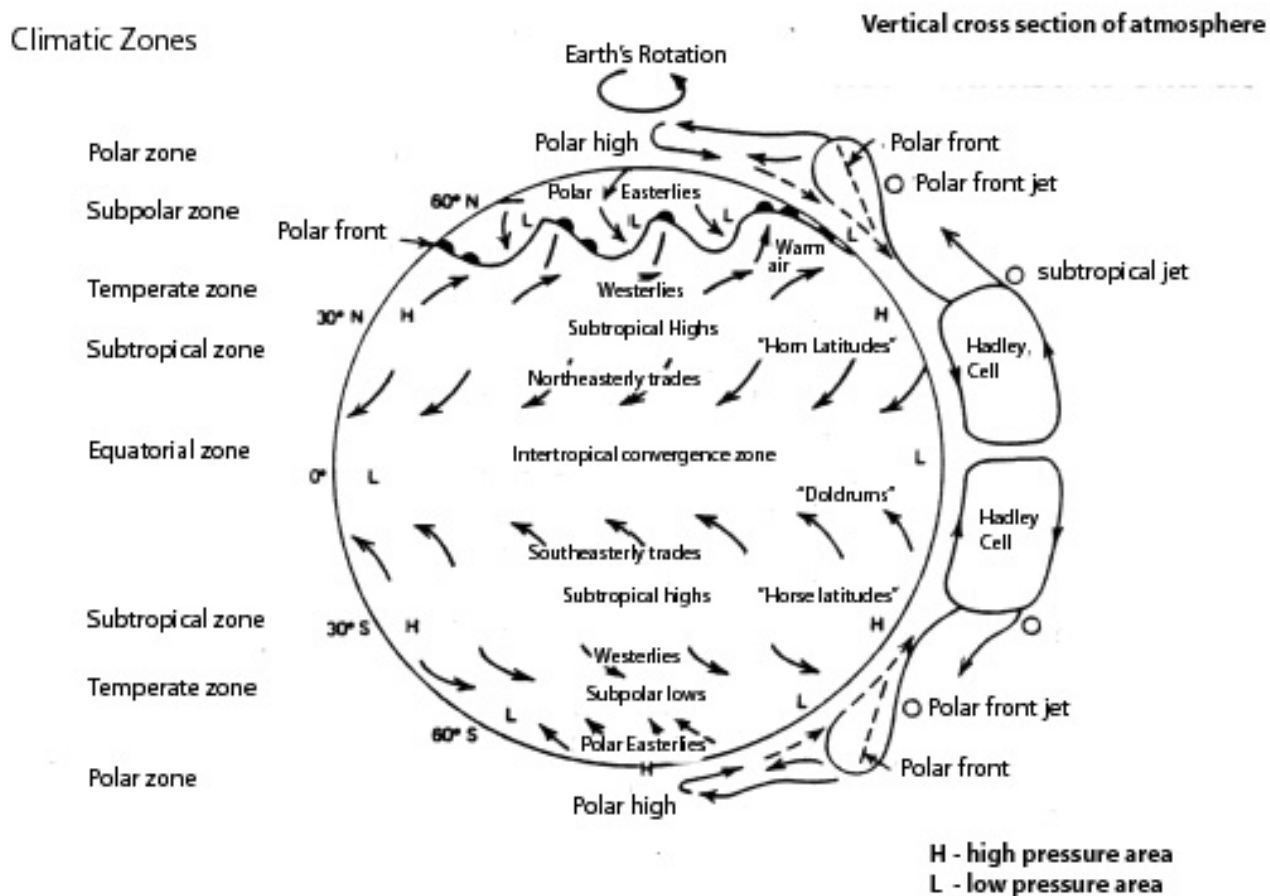

Figure 2.3. The average annual atmospheric surface circulation patterns in different latitude bands. The structure of the meridional circulation cells are in the vertically-exaggerated section to the right. Also note that (a) the meridional component of the zonal winds are exaggerated and (b) wind are named by the direction from which they flow.

Chapter 2 - pg. 4

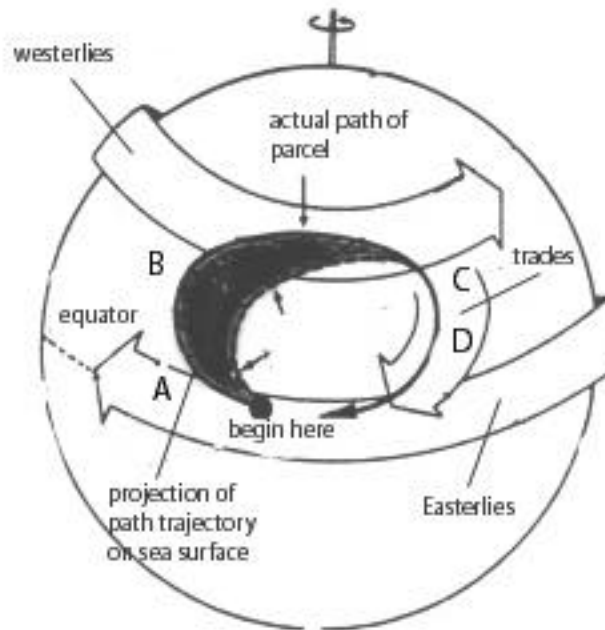

Figure 2.4. The trajectory of an air parcel, the forces that propel it, and the resultant pattern of wind belts around the earth. (Neshyba, 1987)

The Hadley Cell is similar to, but less extensive than our first guess of the meridional circulation on a non-rotating earth. The Hadley Cell is very strongly influenced by *evaporation* and *precipitation* as follows. As the warm dry trade winds sweep over the sea, the air is warmed by the sea surface and becomes saturated with water vapor through *evaporation*. When an “air parcel” is warm enough (in the tropics near region A; see [Figure 2.4](#)), it begins to rise. As the air rises into upper levels of the atmosphere with lower air pressure, the air parcels expand and cool. The cooling lowers the partial pressure at which the air becomes saturated with water vapor. As the air becomes supersaturated with water vapor, condensation occurs, producing clouds and *precipitation*. The condensation process releases latent heat (the heat originally required to evaporate the surface water), which in turn re-warms the air parcel [or prevents it from cooling as rapidly], thereby enabling the air parcel to rise even further. Thus cloudiness is prevalent in this region.

The parcel ceases to rise at B in [Figure 2.4](#), because it has cooled sufficiently to have lost all of its water vapor. This relatively dry, poleward-moving air flow is deflected northeastward by the Coriolis effect; all the while being cooled further through radiation

Chapter 2 - pg. 5

heat loss to space. At C, the cool, dry air converges with the south westward moving air and descends. As parcel air descends, it is strongly heated by compression (due to rising air pressure). By the time the air parcel reaches D it is warm and dry. As air flow turns south westward it begins to pick up evaporating seawater along its path equatorward. Thus Hadley Cell air parcels trace helical pathways, spiraling eastward.

Zone of the Prevailing Westerlies

The mid-latitude *zone of prevailing westerlies* lies between the trade wind zone and the polar front (see [Figure 2.3](#)), which is the boundary between the colder polar easterlies and the warmer prevailing westerlies. A strong upper level atmosphere zonal jet – the so-called *jet stream* - flows along the polar front. The jet stream is a global scale feature that meanders meridionally ([Figure 2.5](#)) affecting the atmospheric circulation that we know of as “weather”. The jet stream contributes to the instability of the subtropical/polar “front” ([Figure 2.6](#)) as well helping to guide the trajectories of the lower atmosphere cyclones and anticyclones which result from the instability.

These pressure systems (the ones you see on the weather maps) are characterized by fluctuating winds associated with counter-clockwise-rotating cyclones and clockwise-rotating anticyclones (schematically shown in [Figure 2.7](#)). These winds – called *geostrophic winds* - have ocean analogs whose Coriolis-influenced dynamics will be discussed later. This zone of strongly fluctuating winds is where the highest rate of poleward heat transport occurs.

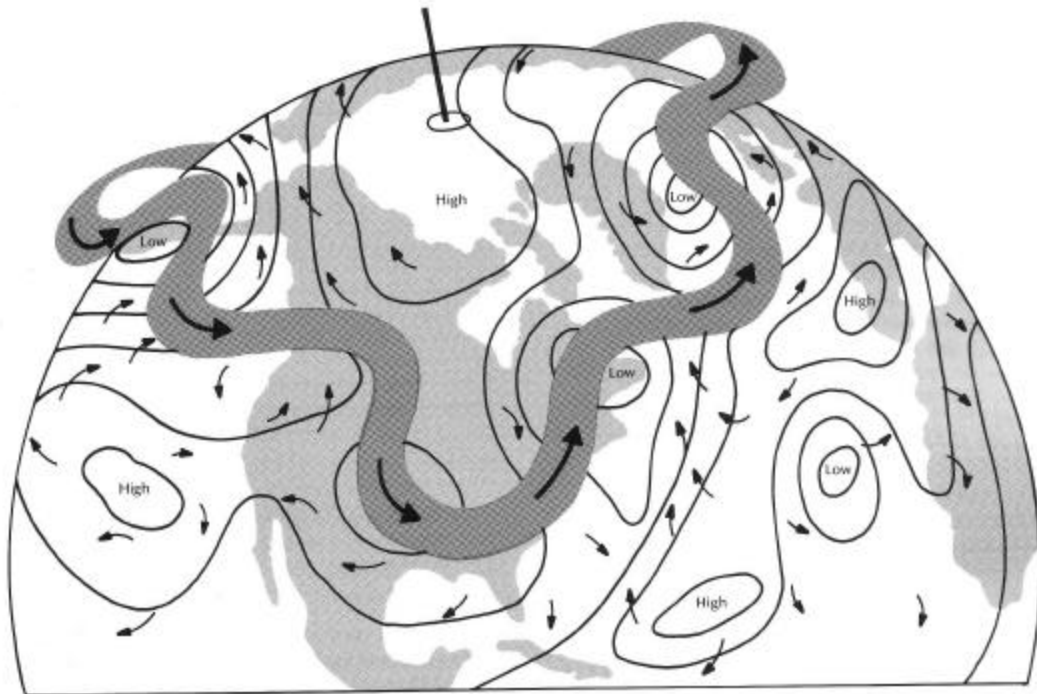

Figure 2.5 The upper-level jet stream in the atmosphere of the Northern Hemisphere. (Neshyba, 1987).

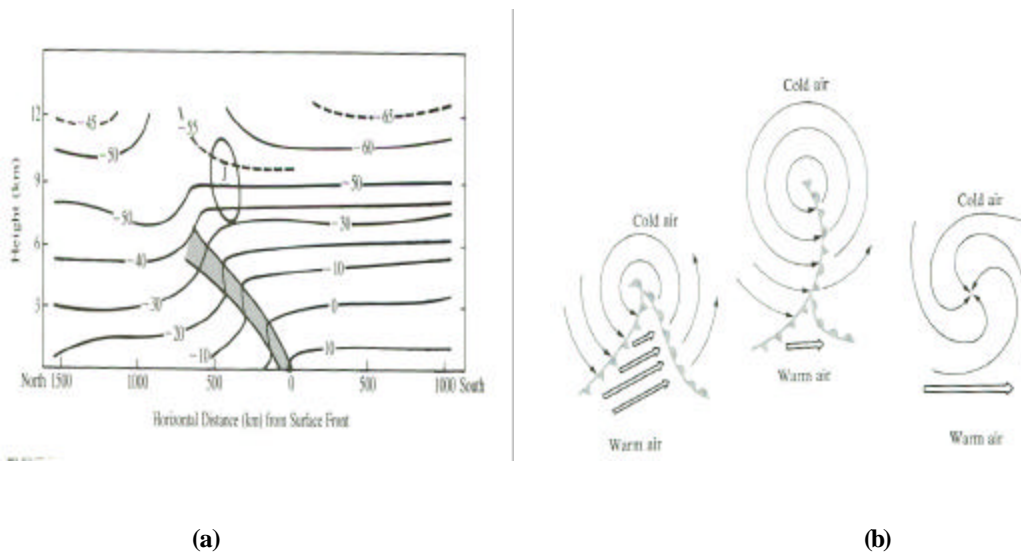

Figure 2.6 (a) A vertical section of the lower level polar front in which the jet stream is located. (b) The development of a cyclone. (Anthes, 1992)

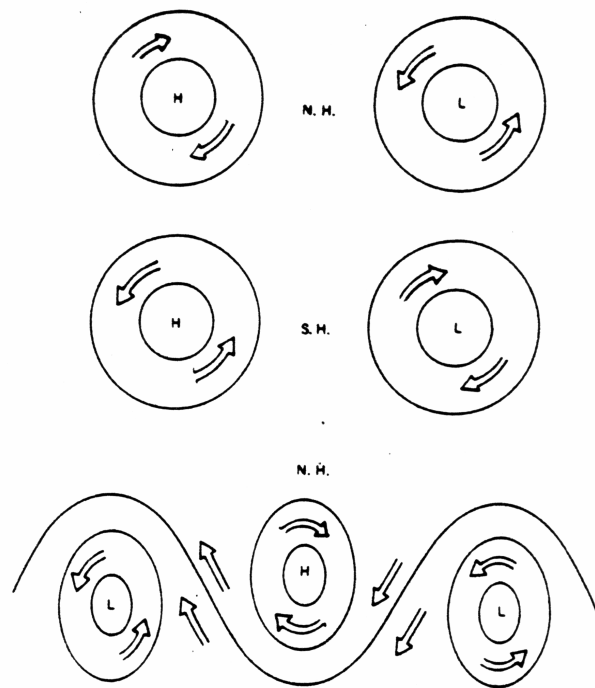

Figure 2.7. Cyclones and anticyclones in the zone of prevailing westerlies. (Knauss, 1978)

Atmosphere / Land Interaction

In reality, the above simple picture of a train of alternating high and low pressure cells is disturbed by the presence of continents especially in the northern hemisphere. In the summer there is a tendency for atmospheric low pressure regions to persist over the warmer land. There is a corresponding persistence of high pressure regions over the adjacent oceans. For example in summer, “southerlies” associated with the well-known Bermuda “High”, pump warm, humid air in the northeastern United States (Figure 2.8a). During the winter, there is a tendency for high pressure over the cooler continental land mass (Figure 2.8b) These perturbations to the simple picture are less evident in the southern hemisphere.

Chapter 2 - pg. 8

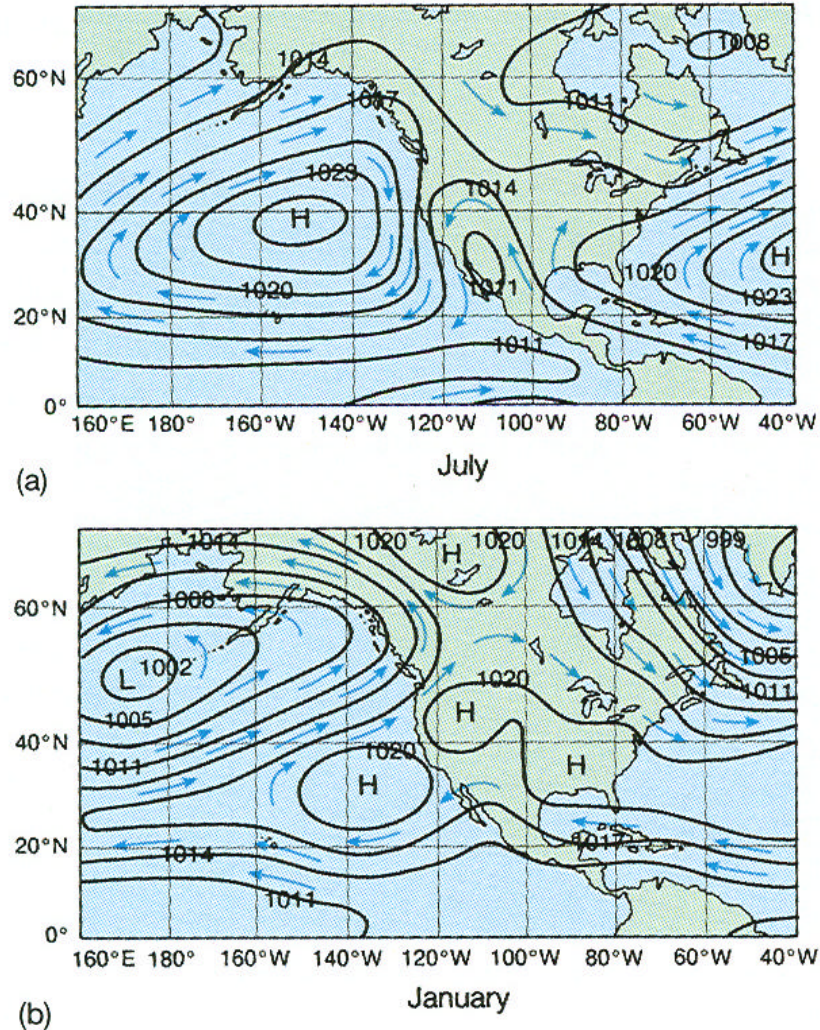

Figure 2.8 Northern Hemisphere (a) Summer - Air flows clockwise around dominant oceanic high pressure cells; (b) Winter - Air flows counterclockwise around dominant low pressure cells. (Duxbury and Duxbury).

Atmosphere / Ocean Interaction

The atmospheric wind patterns described above affect the circulation of the ocean directly through their mechanical forcing of upper ocean currents and indirectly through their heat transfer forcing of changes in ocean water properties. These effects occur on time scales ranging from hours to centuries.

1) WIND FORCING

The winds act on the ocean surface through the stress that they create. Wind stress

Chapter 2 - pg. 9

on the sea surface (τ) is a vector force/unit area that is found empirically to be proportional to the square of the wind speed $|\vec{V}|$ and in the direction of the winds according to the relation

$$\vec{\tau}_s = \rho_a C_D |\vec{V}| \vec{V},$$

where $[\tau_s] = \text{dynes/cm}^2$, ρ_a is the air density $\sim 1.3 \times 10^{-3} \text{ gm/cm}^3$, and C_D is a drag coefficient $\sim 3 \times 10^{-3}$ for wind speed in m/s. For examples,

$$|\vec{V}| = 10 \text{ kts} = 515 \text{ cm/s [20 kts]}$$
$$|\vec{\tau}| = 0.344 \text{ dynes/cm}^2 \left[1.38 \frac{\text{dynes}}{\text{cm}^2} \right]$$

2) SEASONAL FORCING

The winds have an important role in modulating the way in which the upper ocean reflect the seasonally varying air-sea heat transfer processes. Upper ocean temperature and salinity, which are important factors in establishing density gradients or pycnoclines, are affected seasonally (see [Figure 2.9](#)). During the summer, the seasonal thermocline (and hence pycnocline) is strengthened through solar warming ([Figure 2.9a](#)). Fall surface cooling and evaporation produce unstable surface density anomalies that lead to convective overturning, which combines with mechanical mixing, due to the stronger autumn winds, to produce a deepening upper ocean isopycnal (i.e. isothermal, and isohaline) mixed layer. During winter, the cooling-induced convection continues to augment the even stronger winter storm winds in deepening a mixed layer of increasingly cooler water ([Figure 2.9b](#)). During spring, increasingly warmer, wetter storms begin the process of re-establishing the thermocline and corresponding pycnocline.

Chapter 2 - pg. 10

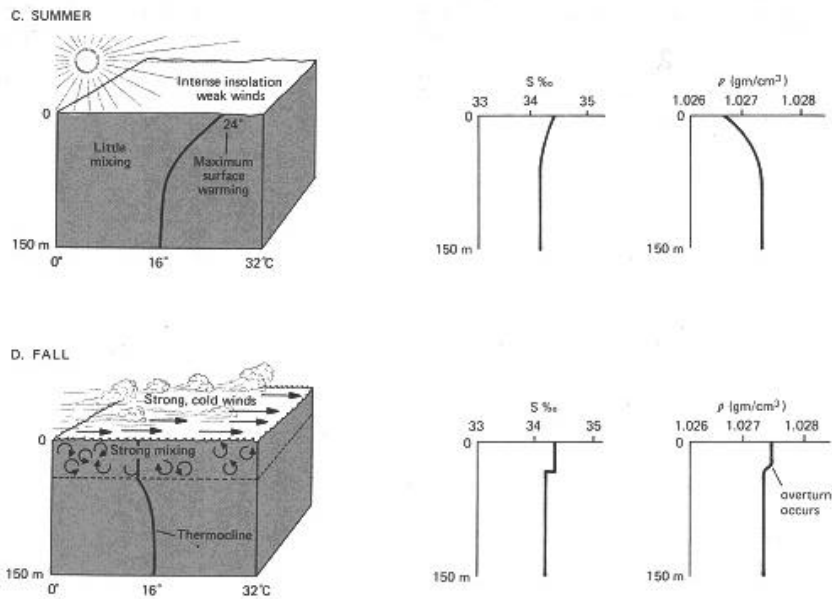

Figure 2.9a. Summer and fall changes in upper water column property structure in response to atmospheric forcing. (Anikouchine & Sternberg, 1973)

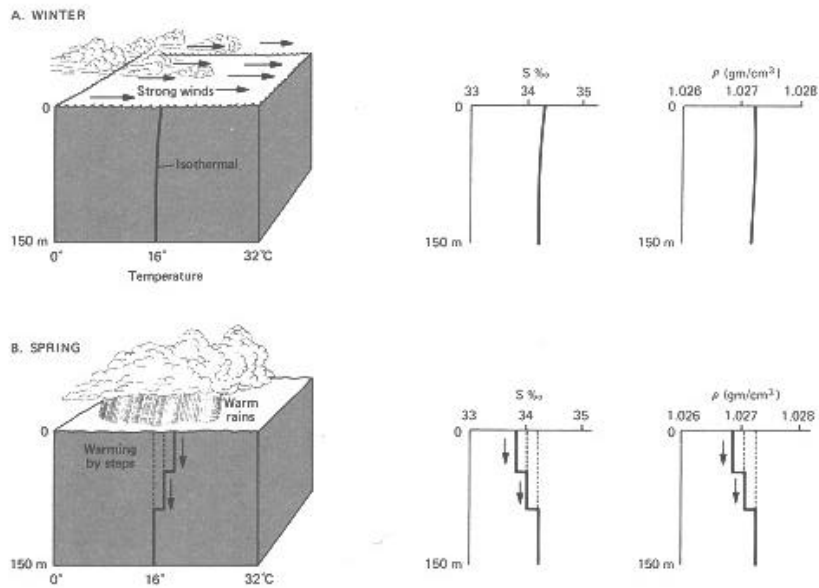

Figure 2.9b. Winter and spring changes in upper water column property structure in response to atmospheric forcing. (Anikouchine & Sternberg, 1973)

3) GLOBAL HEATING-COOLING

The local air-sea interaction processes described in the previous section establish ocean properties consistent with the overhead atmosphere. Hence it is not surprising that global sea surface temperature distribution is primarily zonal (see Figure 2.10); consistent with temperatures produced by the imbalance of incoming and outgoing radiation dominates the system. Still there are seasonally- varying processes which cause seasonal distortions in that dominant pattern as indicated by comparing the panels in Figure 2.10.

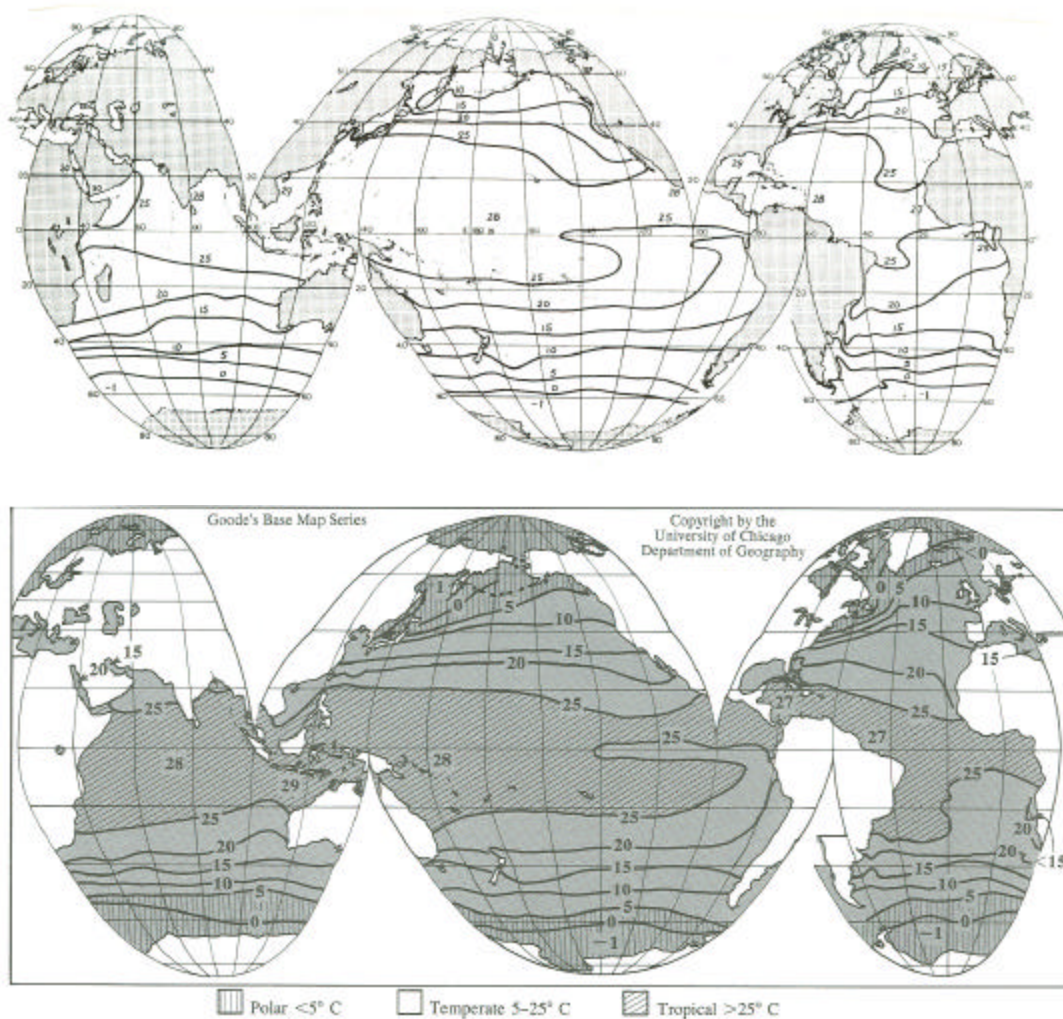

Figure 2.10 Sea surface temperature distributions (above) NH summer; (below) NH winter. (Gross, 1990)

3) GLOBAL EVAPORATION-PRECIPIRATION

Evaporation is relatively large in regions where the warmed dry air is descending in the region of 30°N (or S). High evaporation regions correspond to regions of large loss of latent heat from the sea surface with a corresponding increase in salinity (Figure 2.11).

Precipitation is relatively high in the regions where wet air is ascending; a good example is in the region of the equator 0° and to a lesser extent at 60°N (or S). Excess precipitation over evaporation tends to decrease sea surface salinity. Thus the distribution of surface salinity are much less zonal (Figure 2.11) than temperature distribution.

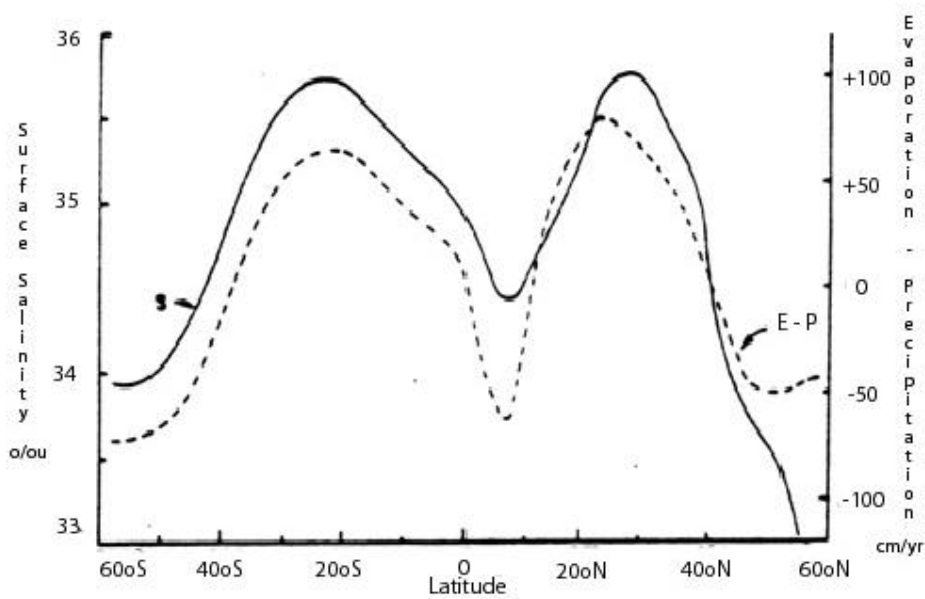

Figure 2.11. Surface salinity (S, average for all oceans) and difference between evaporation and precipitation (E-P) versus latitude. (Pickard and Emery, 1982)

Chapter 2 - pg. 13

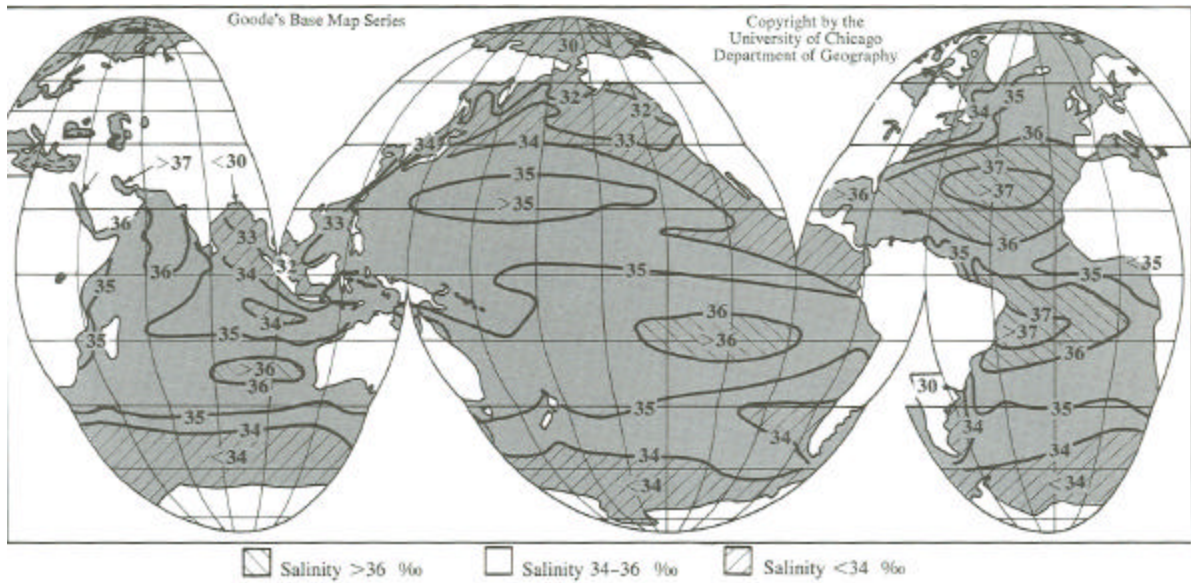

Figure 2.12. Surface salinity distribution (Gross, 1990).